

GMS150TL-N15HDIG-P03-V2

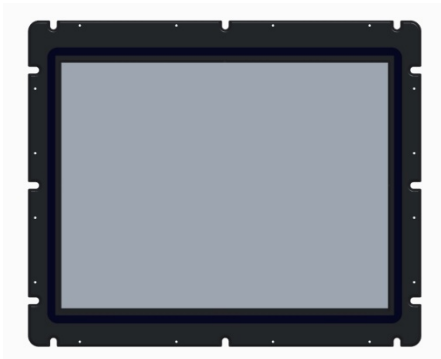

General Description:

GMS150TL-N15HDIG-P03-V2 is one of LCD Touch monitor that using the projected capacitive touch technology, it supports Win7, Win8, Android & Linux by multi-touch function, widely apply to various industrial, commercial and medical devices.

- 1000cd/m2 High brightness ultra-low power LED backlight
- 6mm IK10 cover-glass for public place use
- PCAP Touch with Anti-UV treated
- 10 Multi-touches with water-proof touch function
- 100% designed for outdoor application

Technical details

Product	15" PCAP Touch Monitor	
15" LCD SPEC (G150XTN06.2 with Hear Radiation + Air Flow)	Display Ratio	4:3
	Backlight	LED
	MTBF	50000Hrs
	Active Area	304.128mm x 228.096mm
	Viewing Angle	80°/80°(Left / Right), 70°/80°(Vertical / Horizontal)
	Display Mode	TN, Normally White
	Support Color	16.2M / 262K
	Optical Response Time	Typ. 8ms
	White Luminance	Typ.1200cd/m2 (after 6mm PCAP Min. 1000cd/m2)
	Contrast Ratio	Typ.700:1
	Electrical Interface	LVDS
Display Resolution	1024*768 / 60Hz , 70Hz	

PCAP Touch Panel	Type	Projected Capacitive Multi-Point Touch Panel (EETI 80H60 controller)
	Size	15inch
	Active Area	304.58mm×228.80mm
	Total Thickness	6mm Cover glass (non-AG) with 7H scratch resistance.
	Hardness	7H scratch resistance.
	Surface Treatment	Clear surface
	Anti-vandal Treatment	100% Physical tempered glass
	Consumption	≤0.3W
	Interface Type	USB2.0
	Touch Points	10 Points
	Response Time	≤10ms
	Linearity	≤2%
	Minimum Touch Diameter	1.5mm
	Touch Strength	≤10g
	Touch Panel Life Time	≥200 million Touches
Touch Operation	Finger or touch pen	
Compatible O/S	WinXP, Win7, Win8, Windows10, Window11, Mac, Android, Linux	

Monitor Specification	Outline Dimension	366.00mm×303.00mm×58.70mm
	Product Construction	Open Frame with plastic bezel
	Product Color	Black with galvanized silver
	Environment Parameter	Operation: -30°C ~85°C Storage: -30°C ~85°C Operating Humidity: 20%~90%
	Interface	VGA, DVI, HDMI, USB (for touch), 24VDC (Phoenix1825514)
	IK / IP Protection Level	IK10 / IP65 (front)
	Heat Radiation	Natural Air Cooling
	Input Voltage	24VDC
	Shipping Weight	Box dim.= 482*231*431(mm), Box Weight = 9.22Kg, 1 Box = 2 Pcs
	Warranty	12 months
	Certification	CCC, CE, FCC, RoHS

Accessories

USB Touch cable	USB-05-1800-V1.1	*1 Pcs	1800mm length
HDMI cable	HDMI-19-1800-V1.1	*1 Pcs	1800mm length

Product Photo



Technical drawing

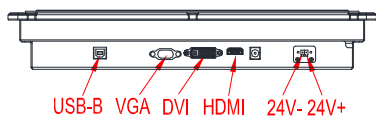
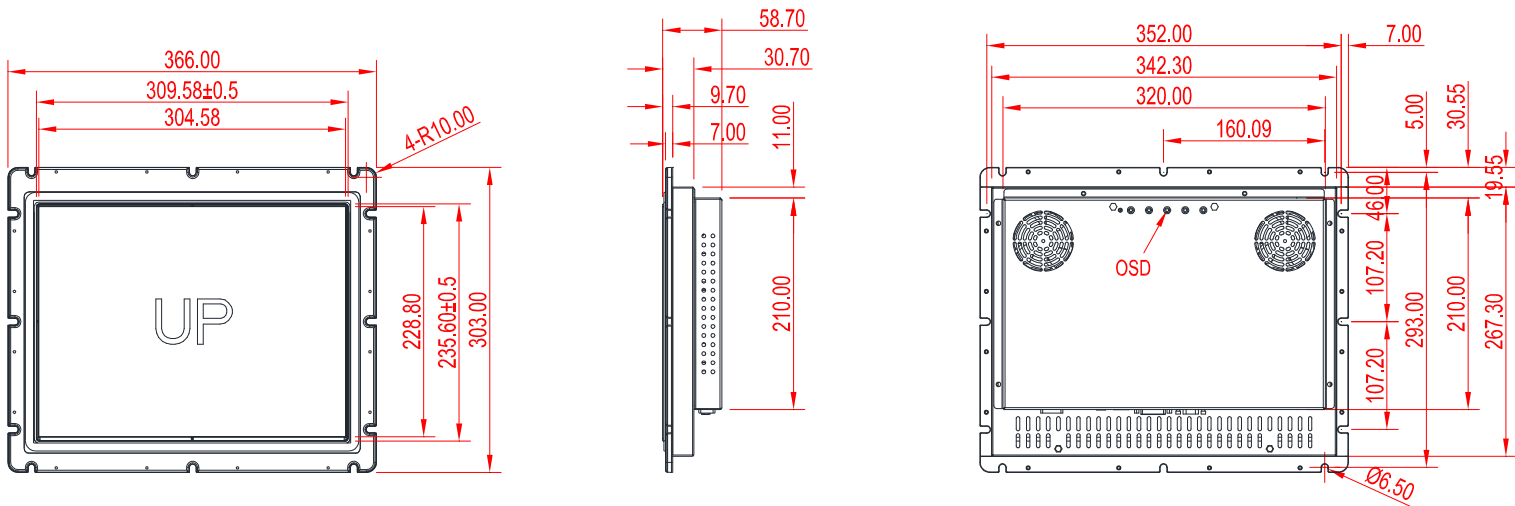

Carton Package

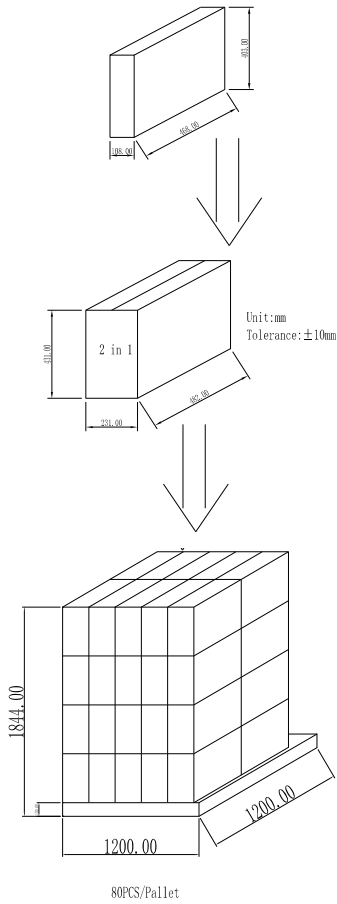

Notes:

1. Package : 2 Pcs 15" LCD monitor / per carton
2. Internal Package: 468(L) mm x 108(W) mm x 403(H) mm
3. Max. Weight: 9.22 Kg / per carton
4. Outside dimension of carton is 482(L) mm x 231(W) mm x 431(H) mm
5. Pallet Quantity: 80 Pcs 15" LCD monitor
6. Pallet Dimension: 1200 (L) mm x 1200(W) mm x 1844 (H) mm